



WORKSTATION SCREENS

May 1, 2020

teknion

Created to support the changing office environment, this resource will help identify the best solution for your screen needs.

Through a combination of Teknion standard and special offerings, we can provide a range of options to fit unique challenges and configurations.



01

DESK SCREENS

All desk screen heights options:

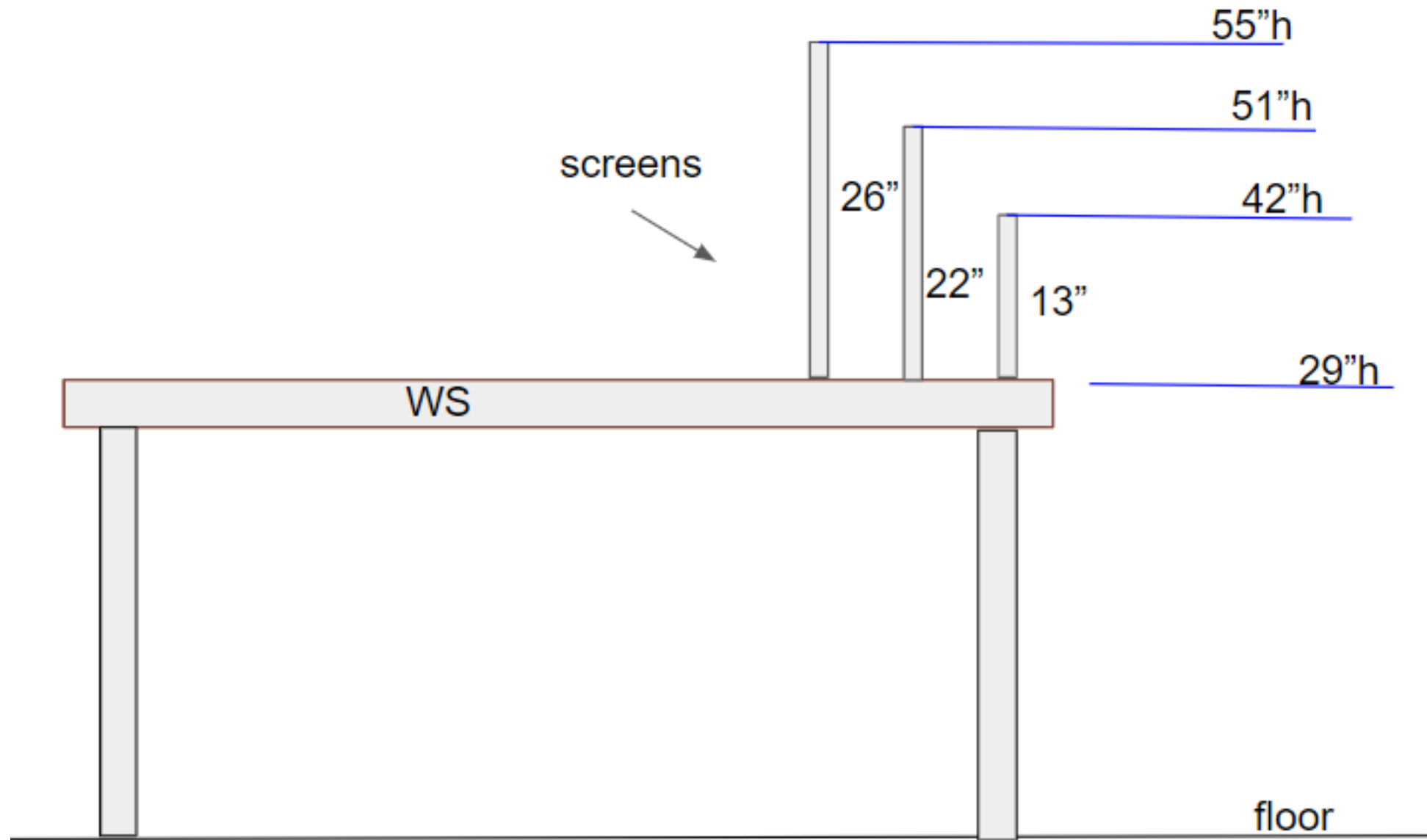

Desk mounted

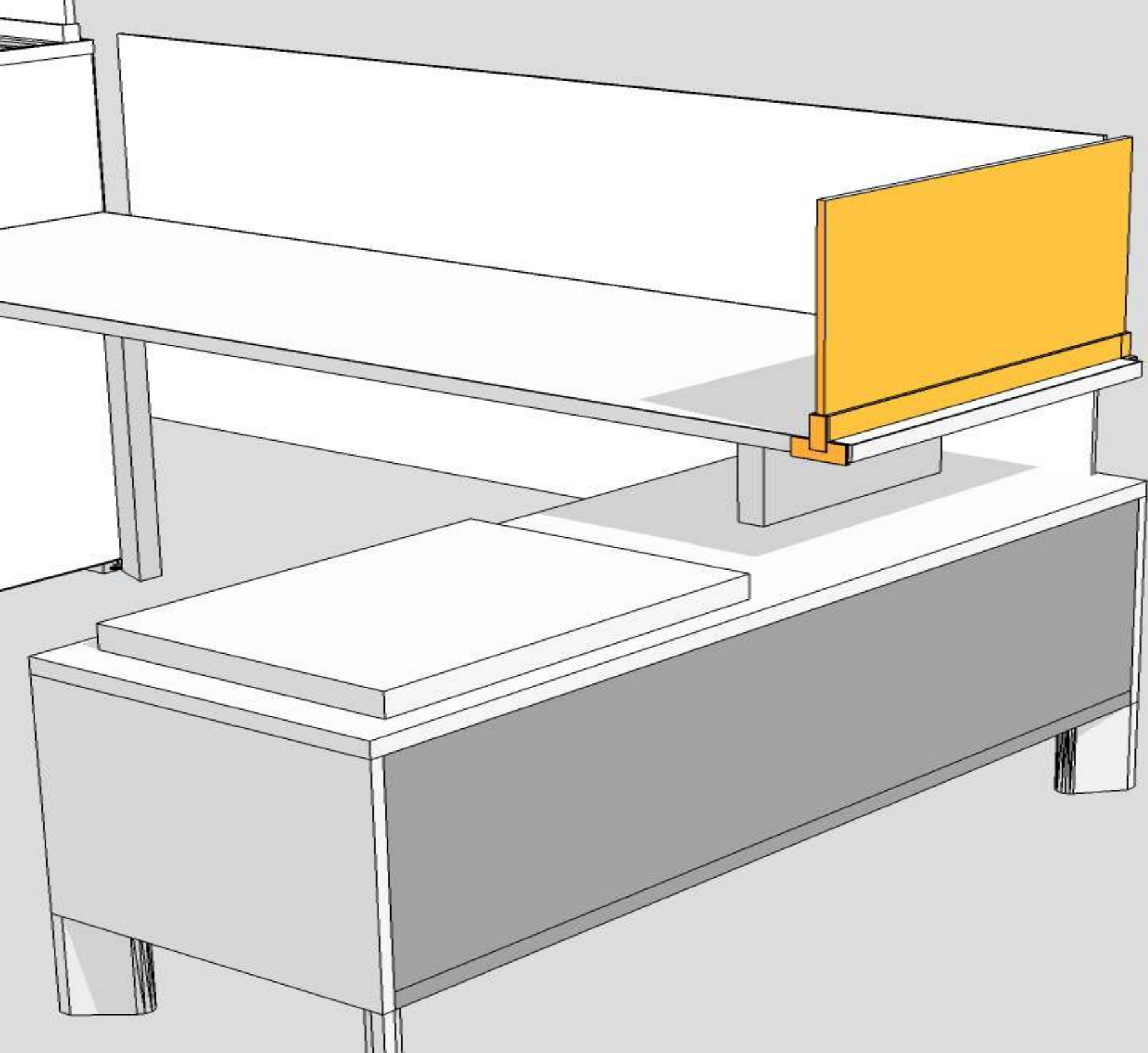

Desk-top

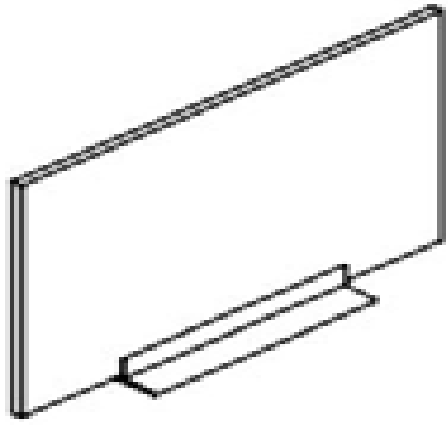

UNSDT: Desk-Top Casual
Screen

Materials:

Seamless
Source Laminate
Smooth Felt
Acrylic

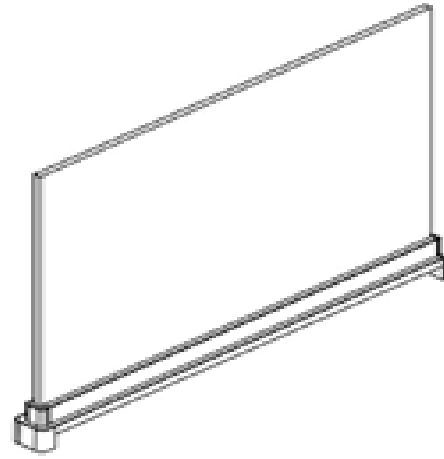

GNSD: Solid Lateral Screen

Materials:

Seamless
Source Laminate
Smooth Felt
Acrylic

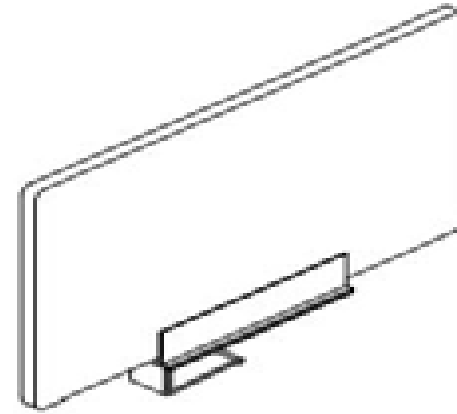

WWCR: Lateral Casual
Screen

Materials:

Seamless
Source Laminate
Smooth Felt

Desk-top
DES
D

* Product codes shown are examples which can be used when creating CRs.

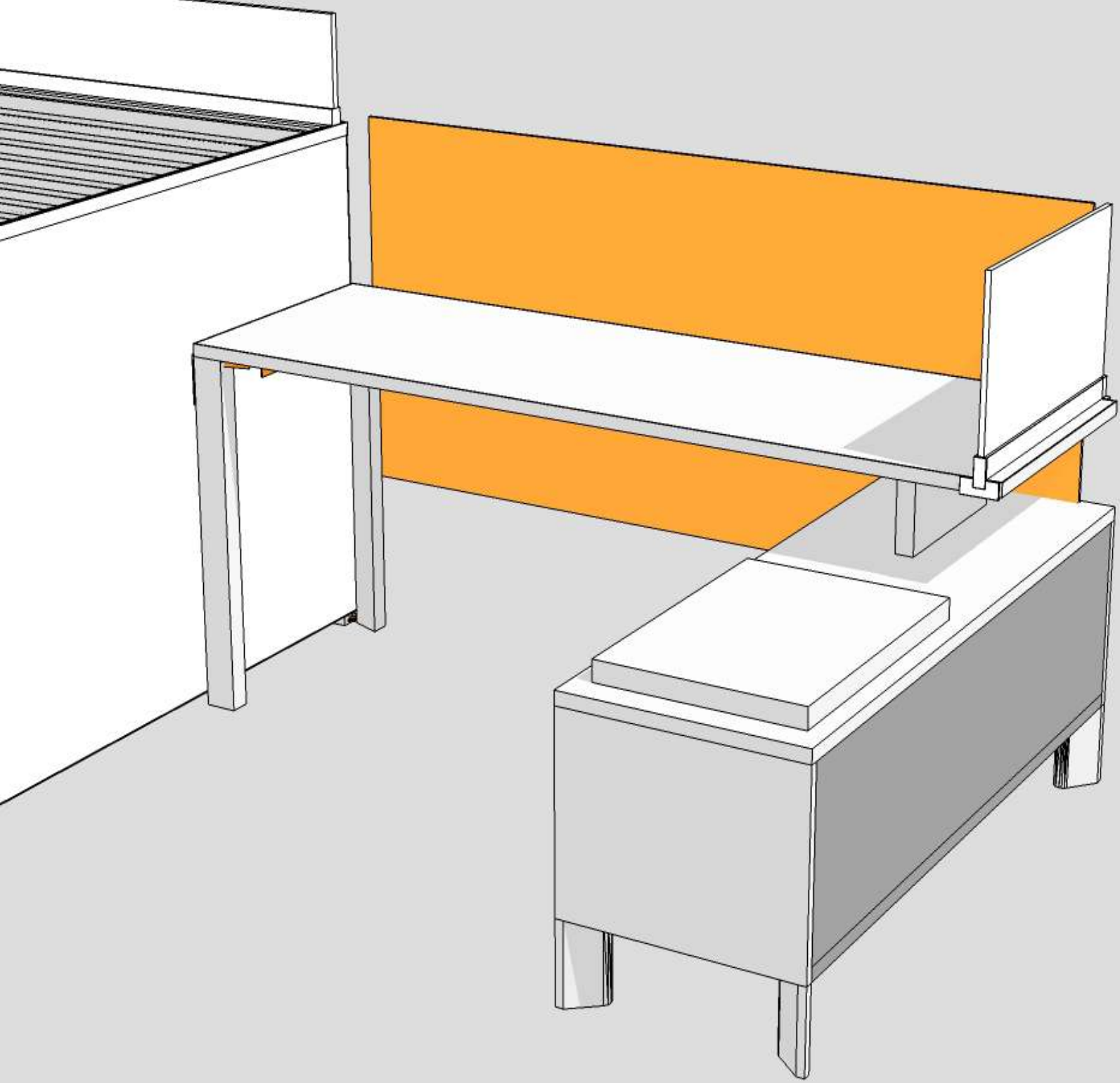

Desk-edge

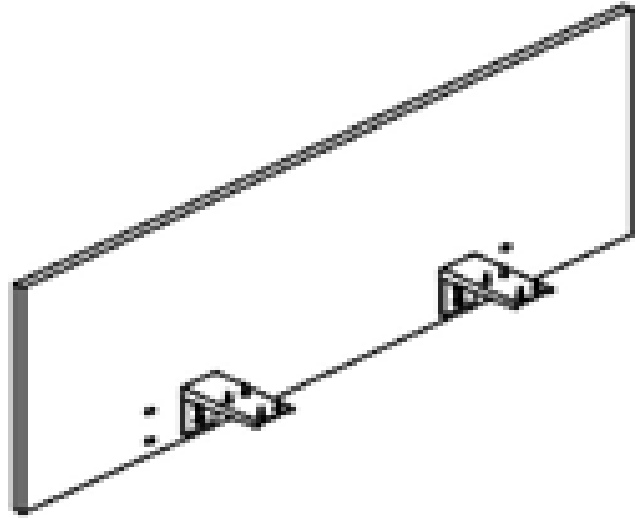

UNSDE: Desk-Edge Screen

Materials:

- Seamless
- Source Laminate
- Smooth Felt (GZDH)
- Acrylic (UNSDEG)

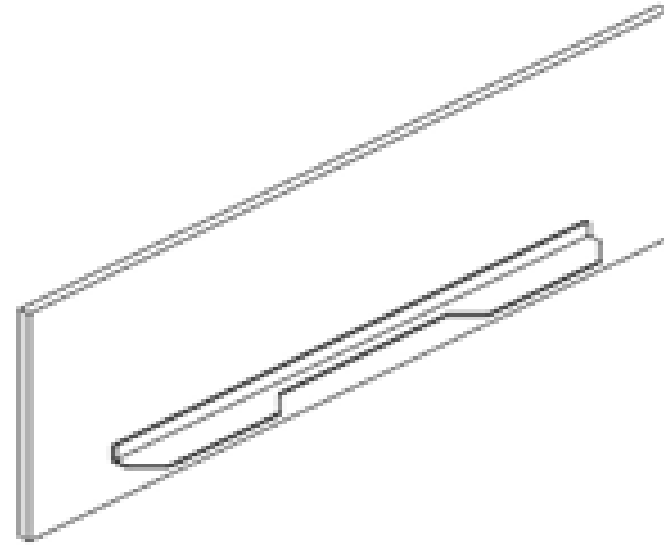

GNSD: Solid Lateral Screen

Materials:

- Seamless
- Source Laminate
- Smooth Felt
- Acrylic

* Product codes shown are examples which can be used when creating CRs.



1. WORKSURFACE DEPTH



2. EXTENDED DEPTH

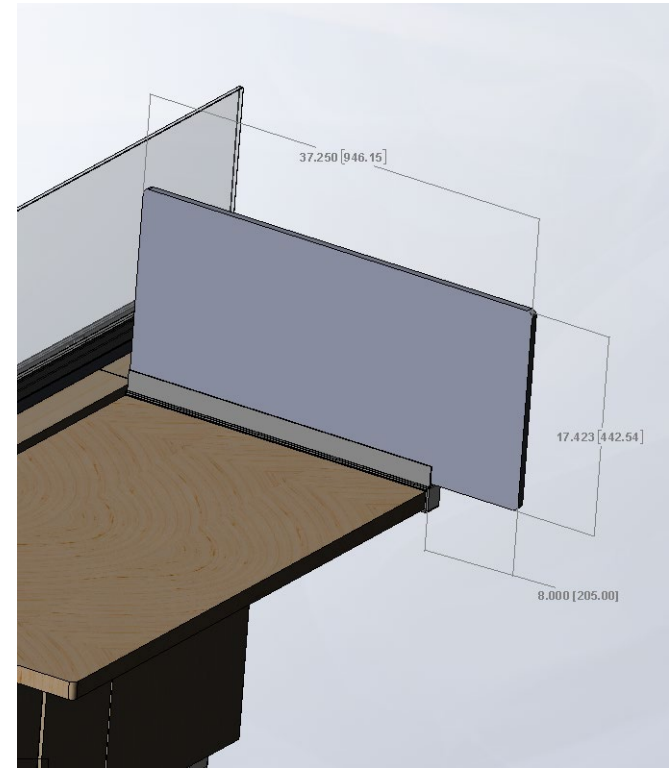

18" HIGH X 37.25" DEPTH
SCREEN – EXTENDS 8"
PAST USER EDGE

Desk-edge

Combination of Desk-Edge and Desk-Top

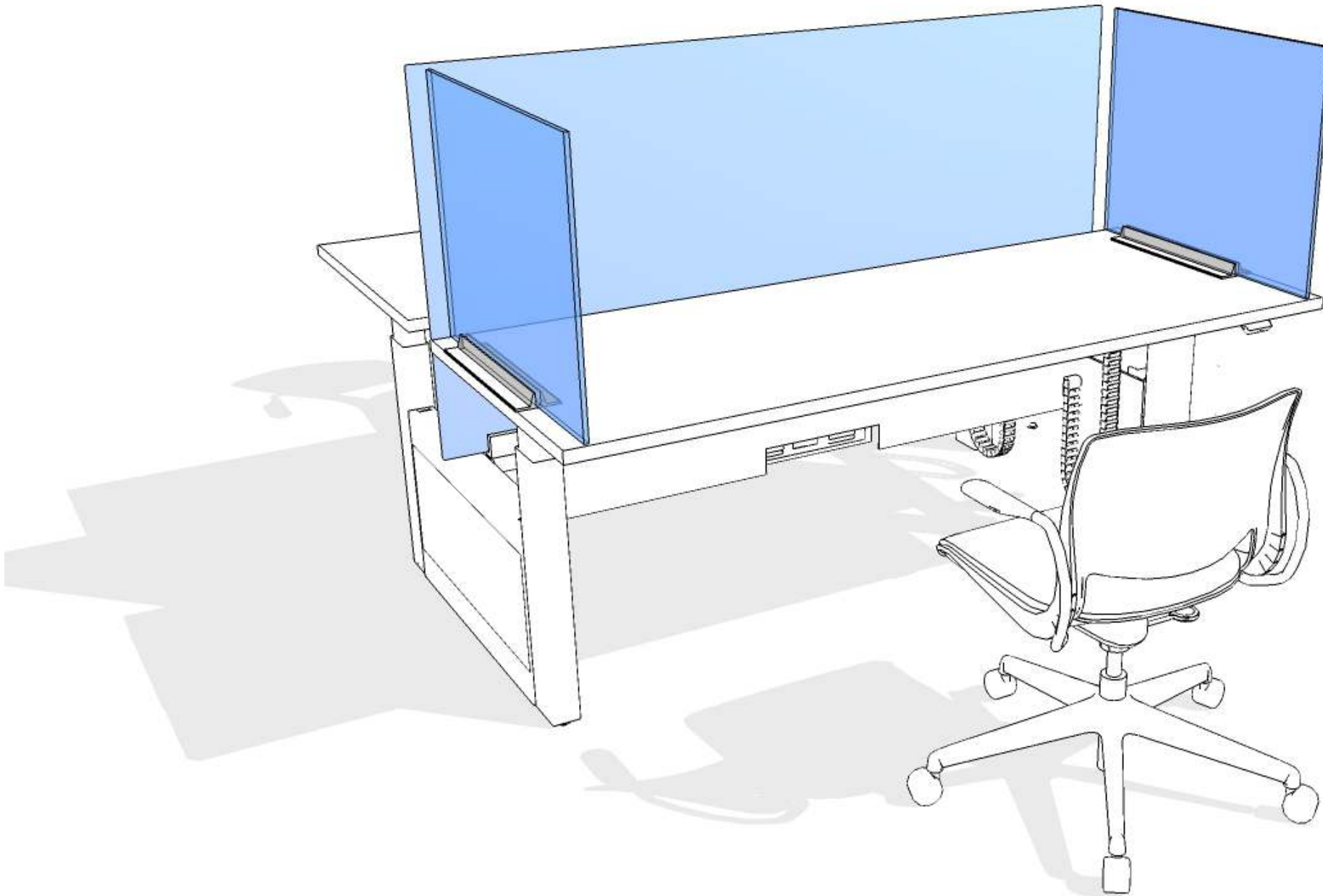

Desk mounted

Worksurface L-screen Kit

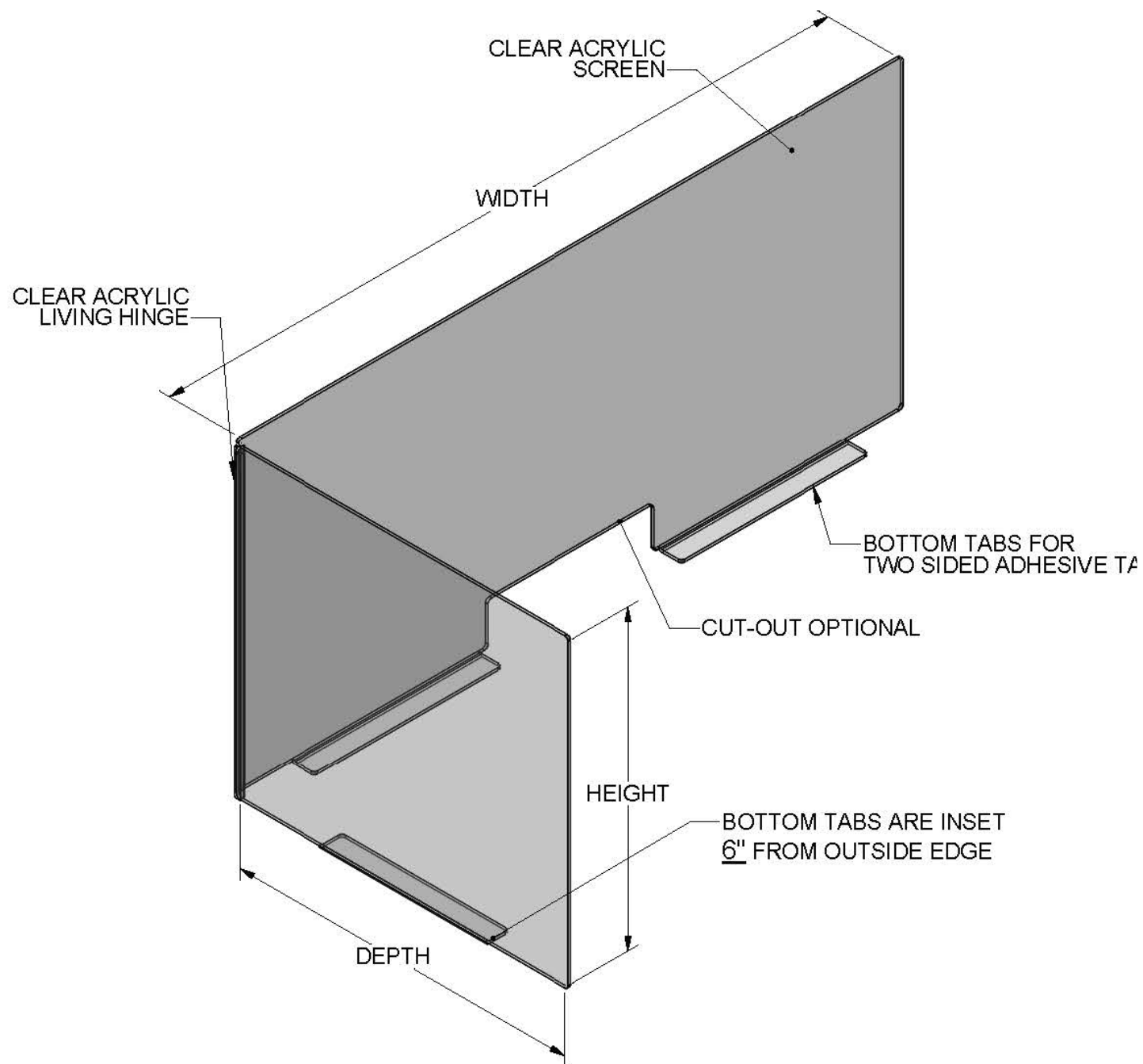

Desk-top

Worksurface U-screen Kit

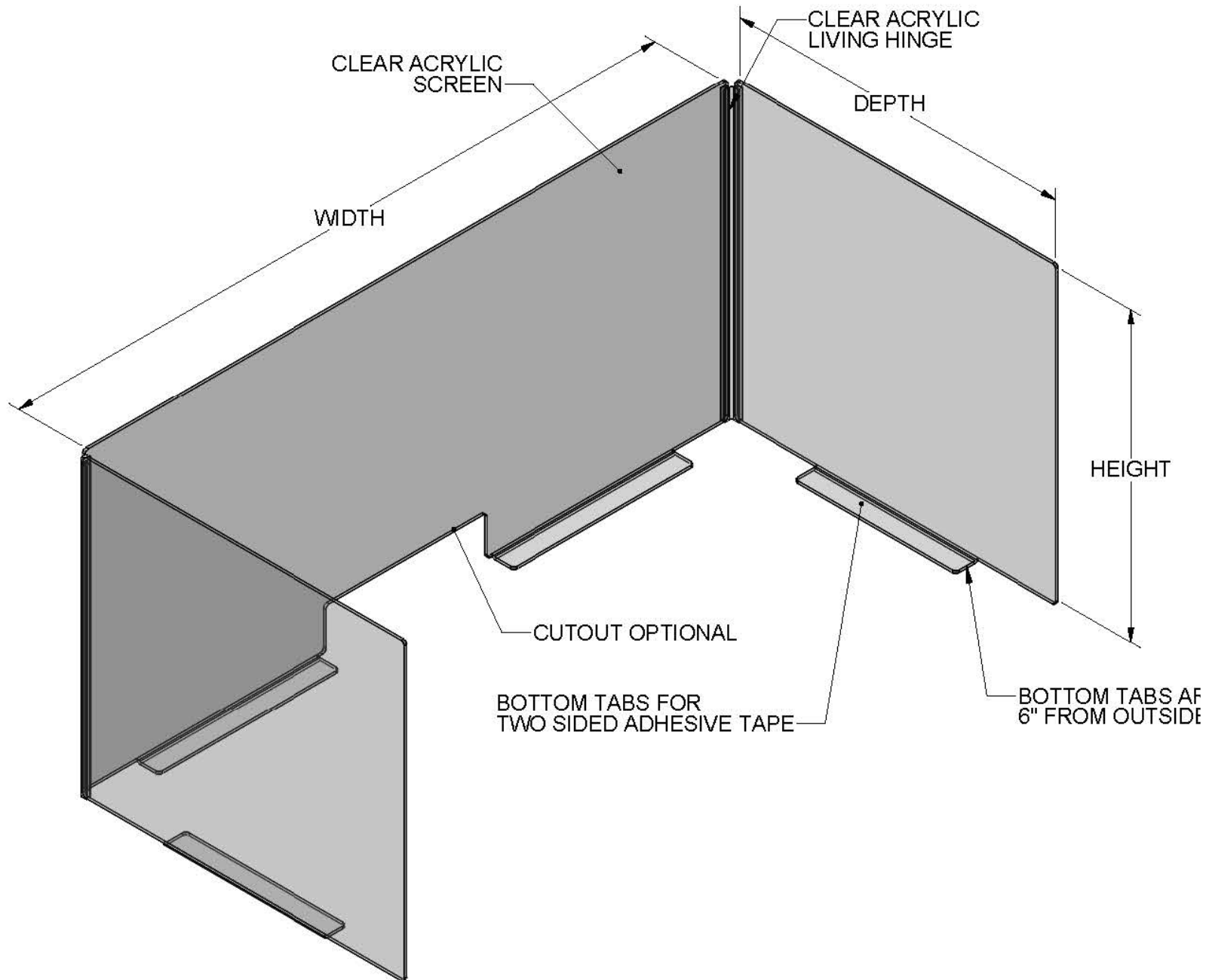

Desk-top



02

FLOOR SCREENS

All floor screen height options:

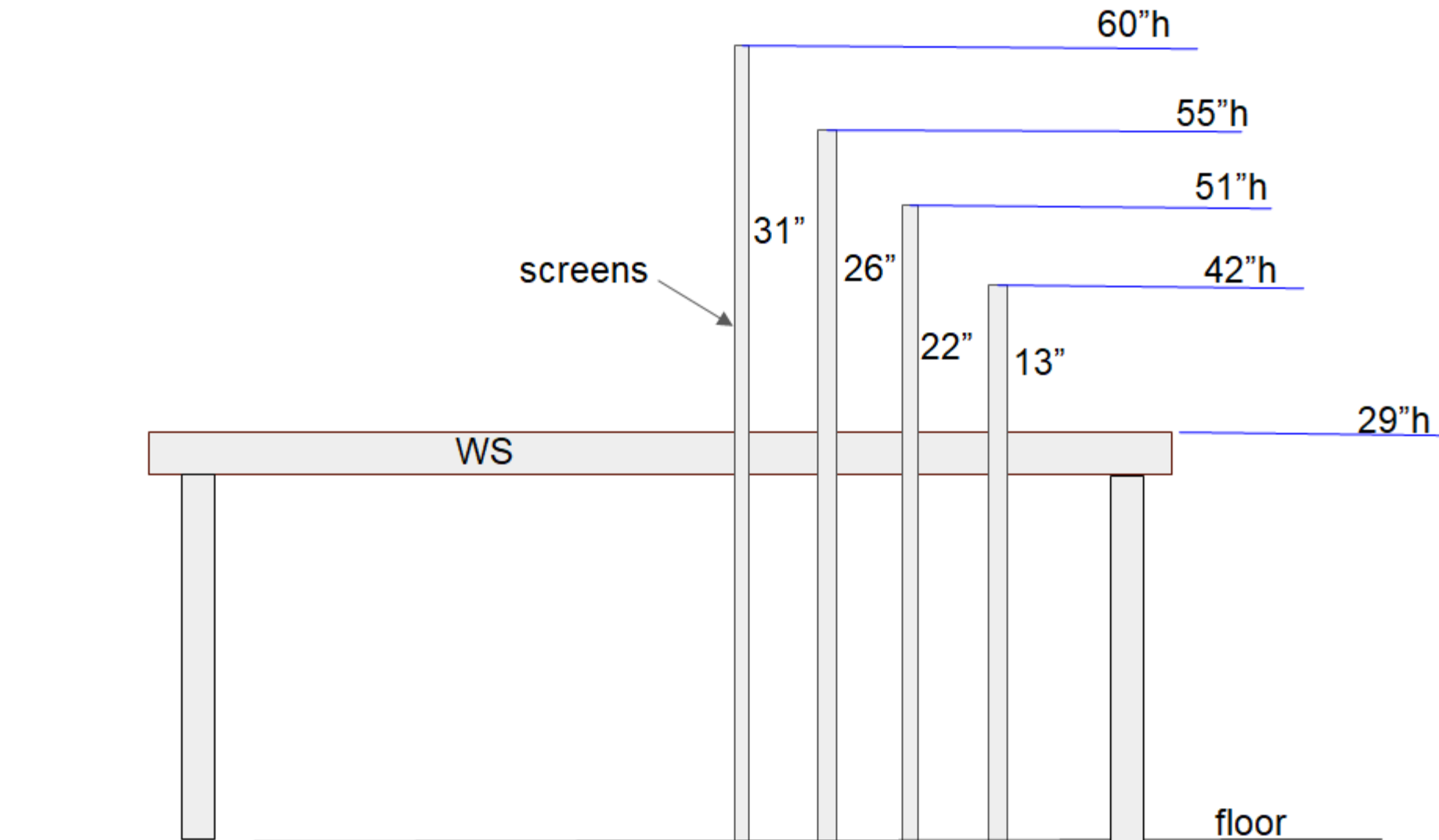

Floor Screen

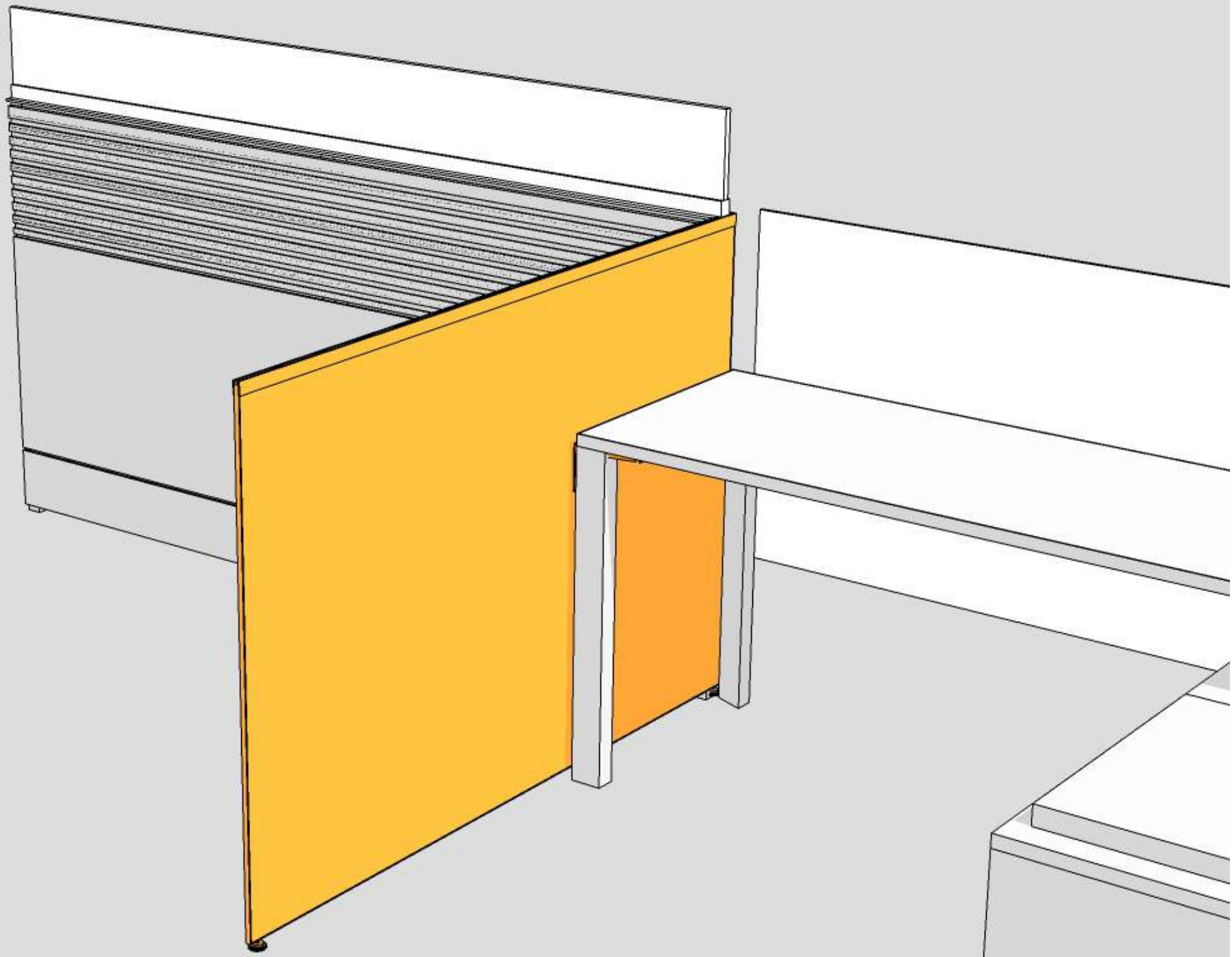

Floor Screen

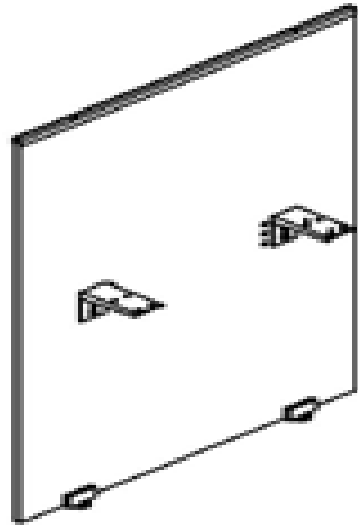

UNSF: Floor Screen

Materials:

Seamless
Source Laminate

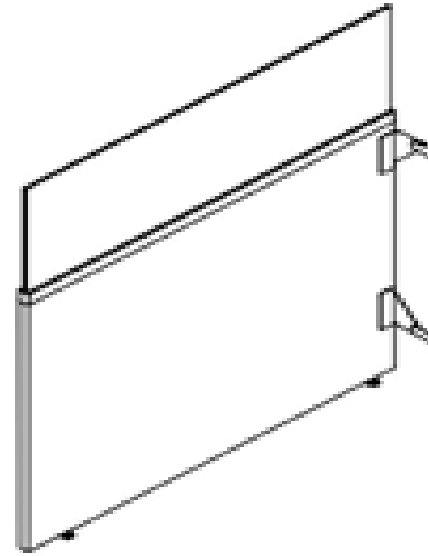

UALSG/S: Lateral Screen with or without glass

Materials:

Seamless
Source Laminate

* Product codes shown are examples which can be used when creating CRs.

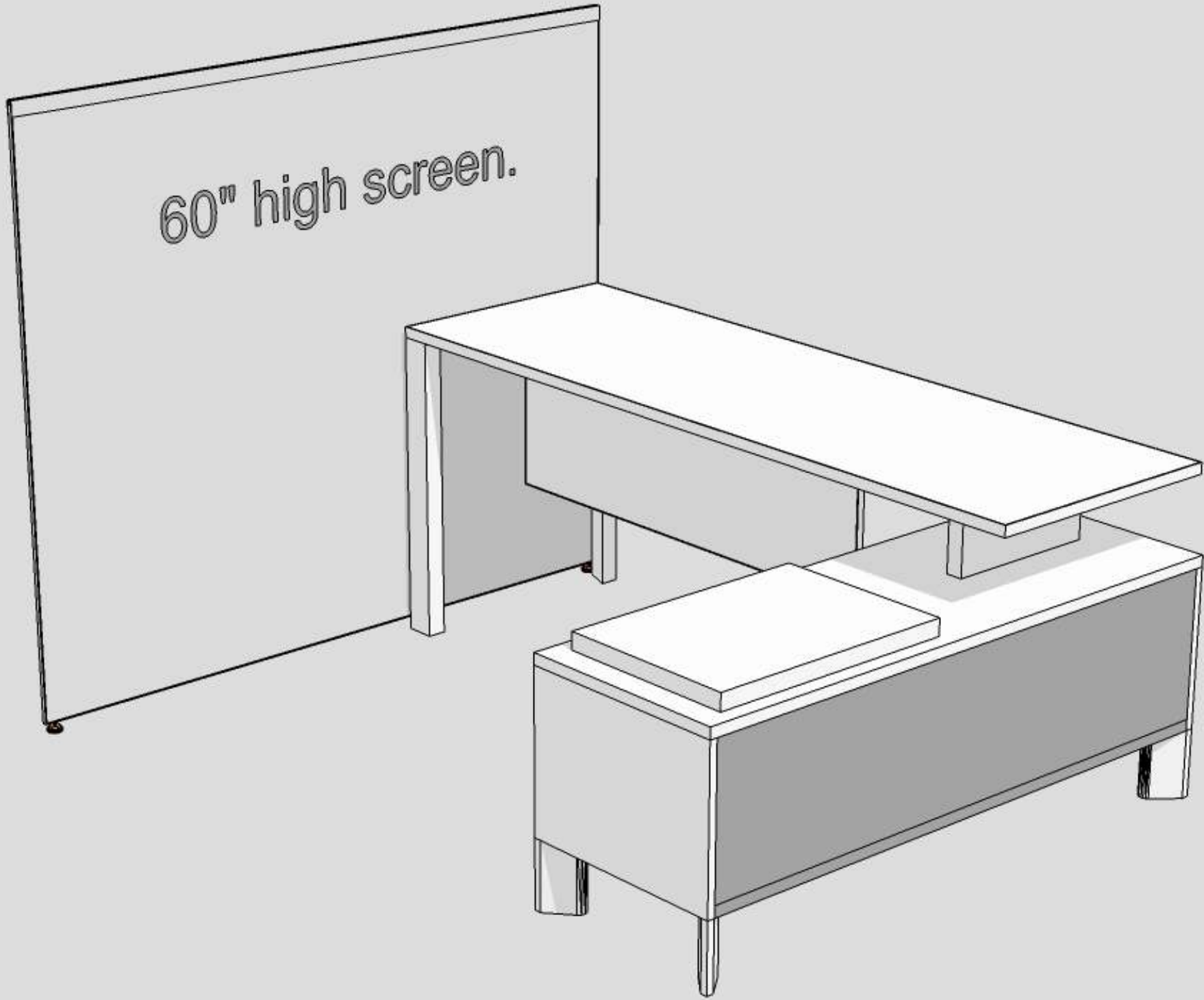

Floor Screen



03

PANEL ADD-ON SCREENS

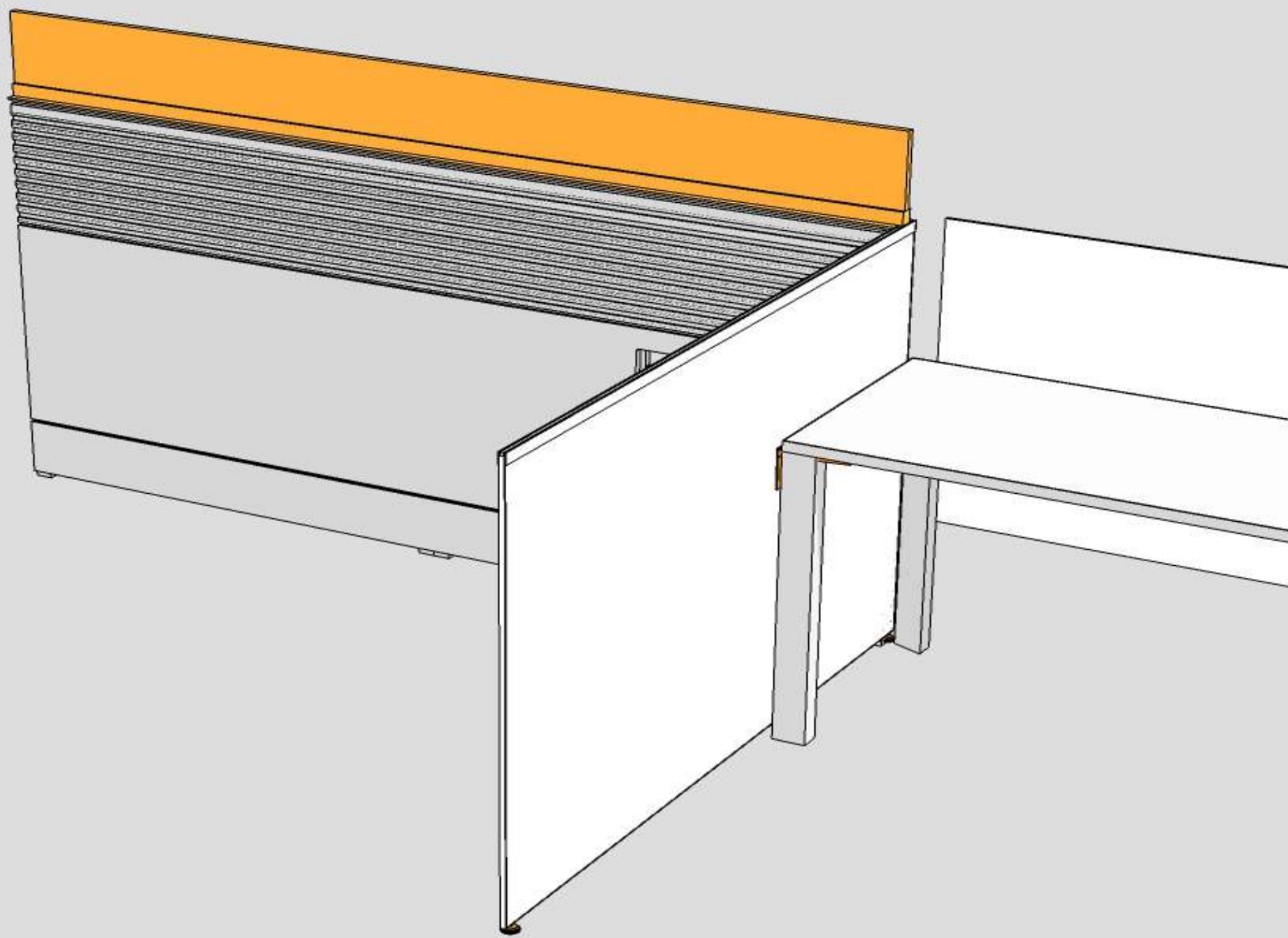

Panel add-on

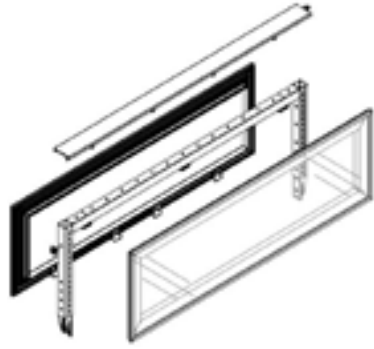

UNSPG: Panel Wall Add-On Screen

UNPWSR: Panel Add-On Stacker

KPGA: Panel Add-On Screen

Materials:

Seamless
Source Laminate
Acrylic

Materials:

Metal Frame Only

Materials:

Acrylic

* Product codes shown are examples which can be used when creating CRs.

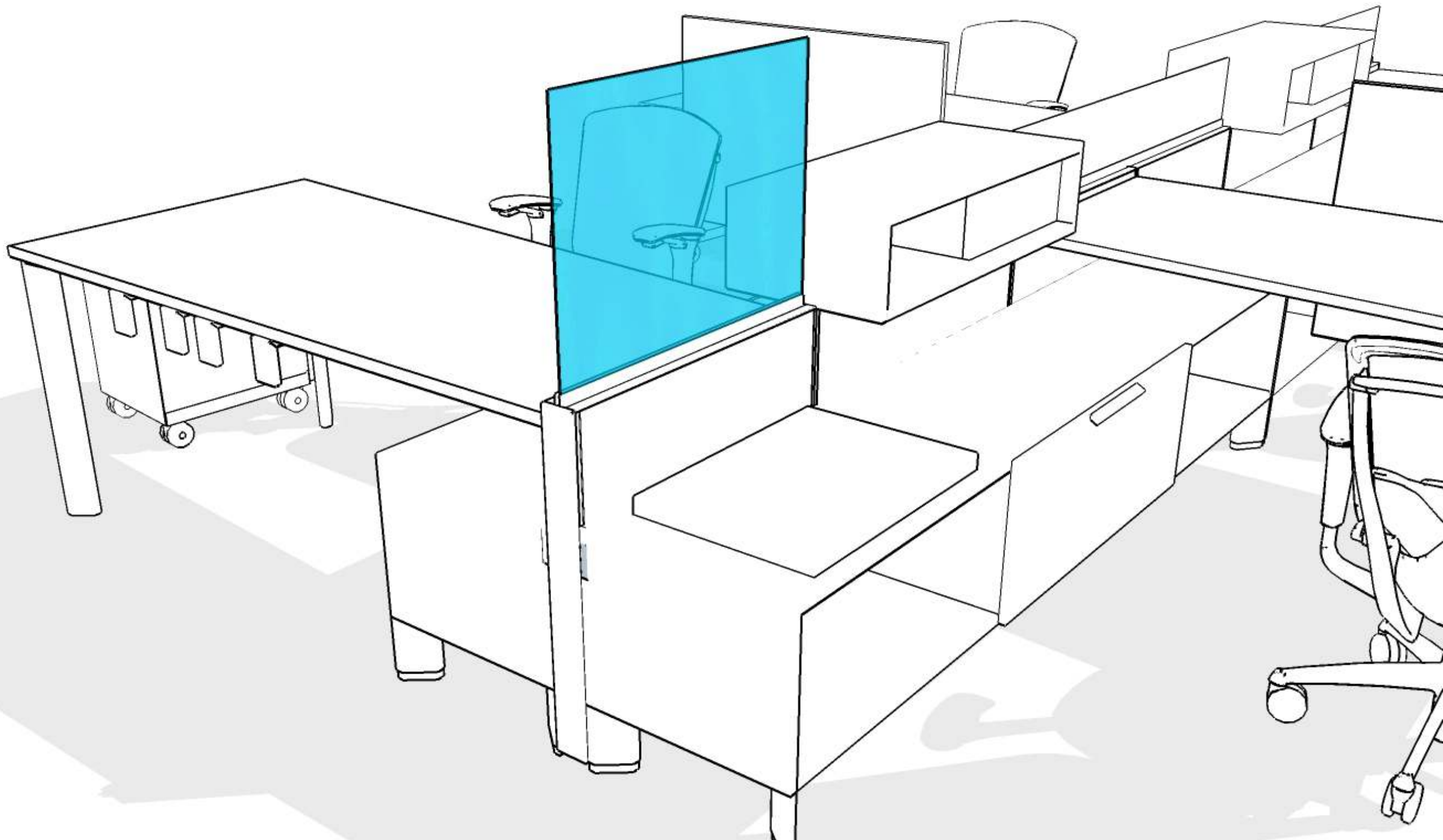



TEKNIOR