



WORKSTATION SCREENS

May 1, 2020

teknion

Created to support the changing office environment, this resource will help identify the best solution for your screen needs.

Through a combination of Teknion standard and special offerings, we can provide a range of options to fit unique needs and configurations.



01

DESK SCREENS

All desk screen heights options:

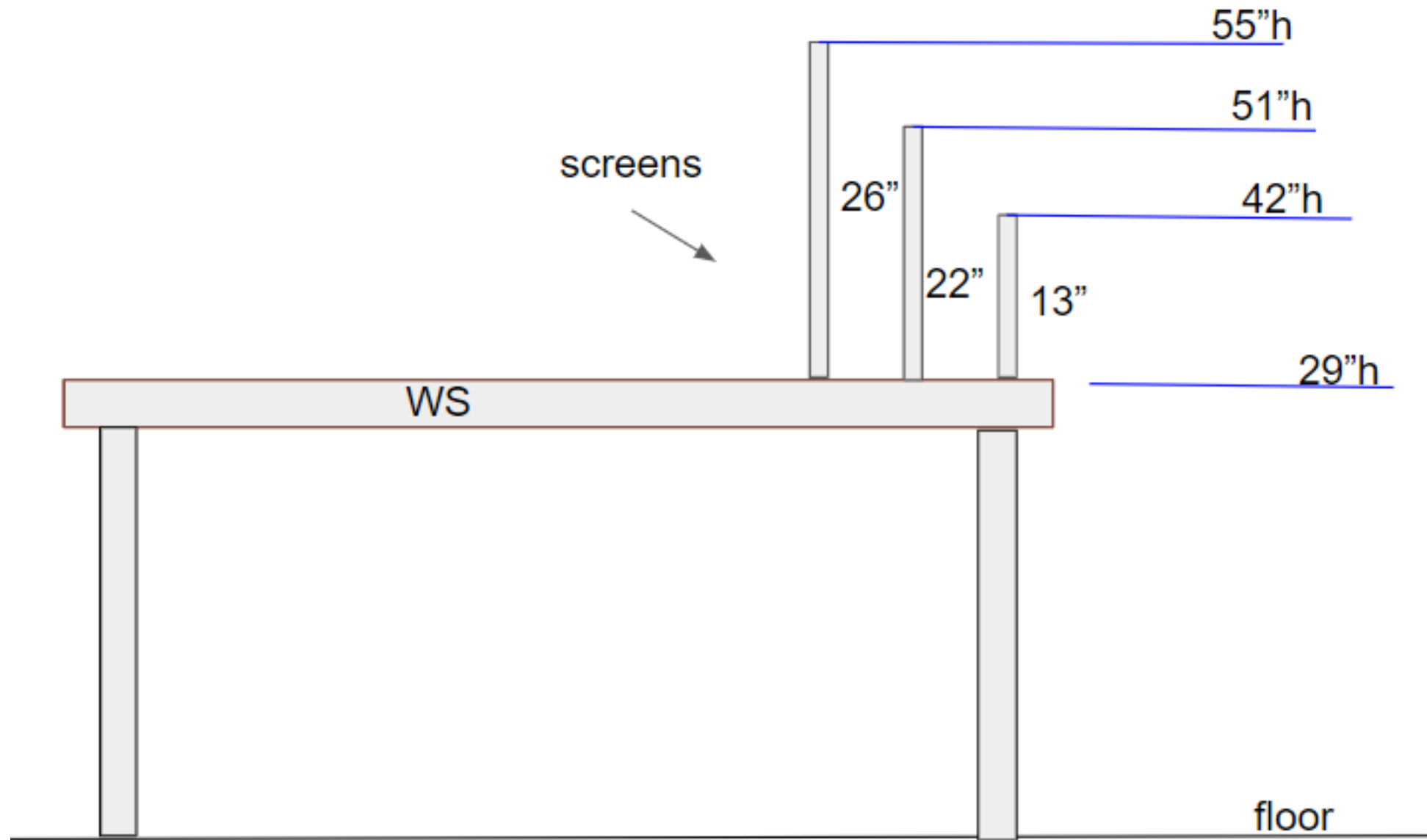

Desk mounted

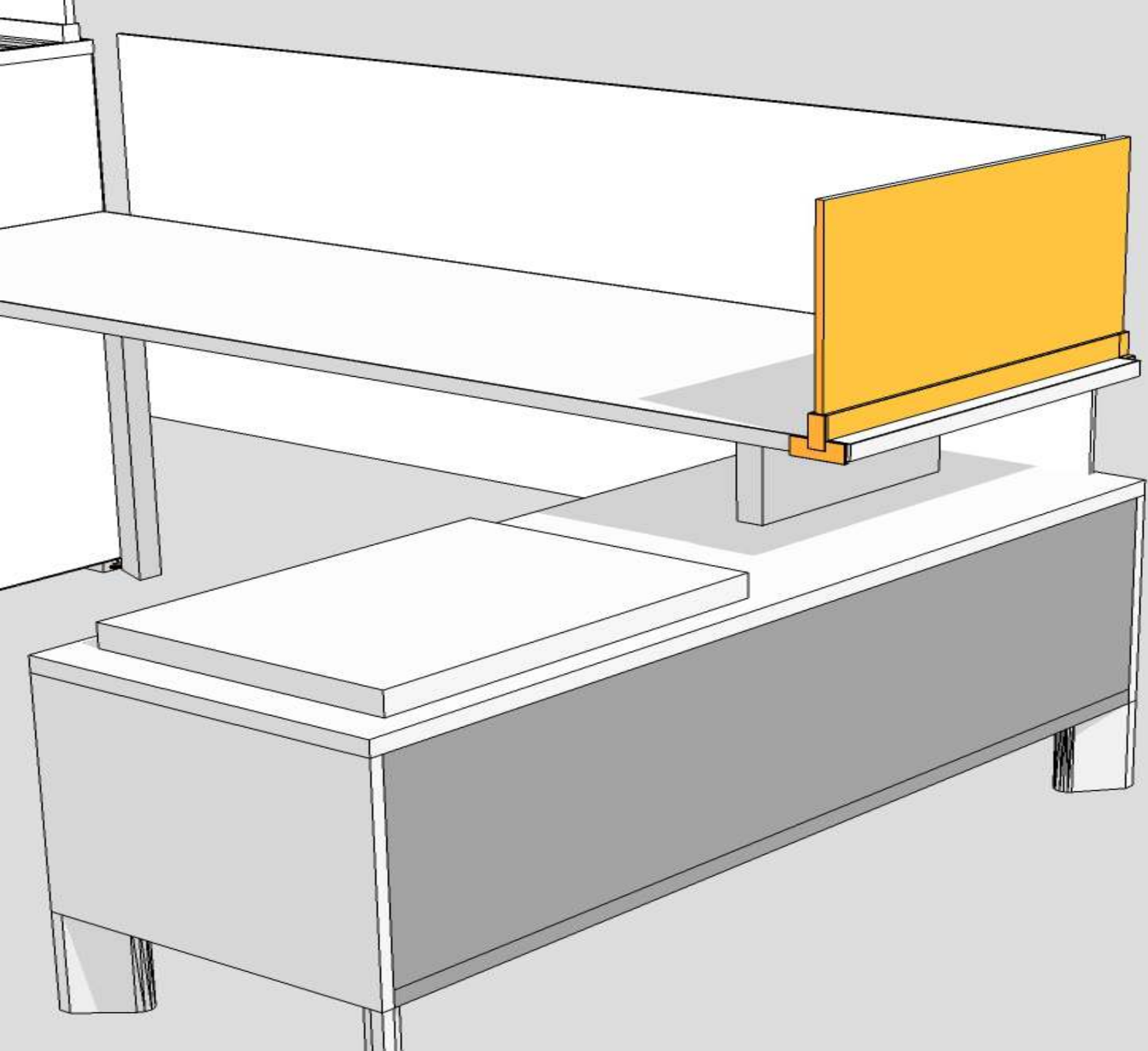

Desk-top

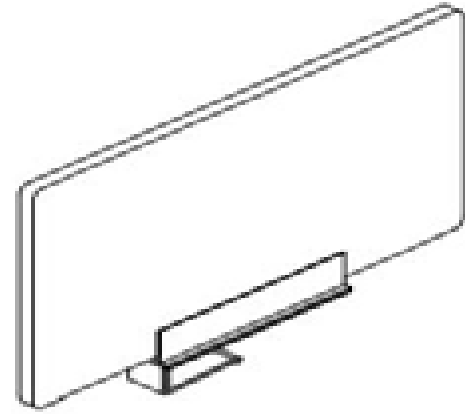
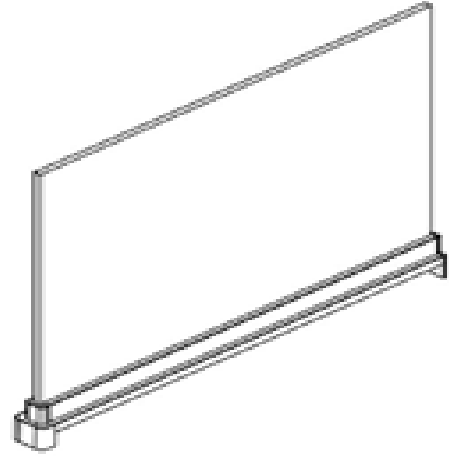
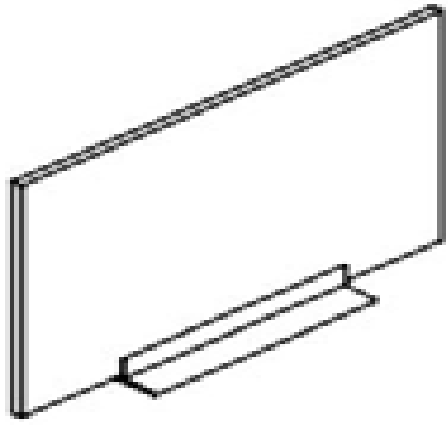

UNSDT: Desk-Top Casual Screen

GNSD: Solid Lateral Screen

WWCR: Lateral Casual Screen

Materials:

- Seamless
- Source Laminate
- Smooth Felt
- Acrylic

Materials:

- Seamless
- Source Laminate
- Smooth Felt
- Acrylic

Materials:

- Seamless
- Source Laminate
- Smooth Felt

Desk-top
DES
D

* Product codes shown are examples which can be used when creating CRs.

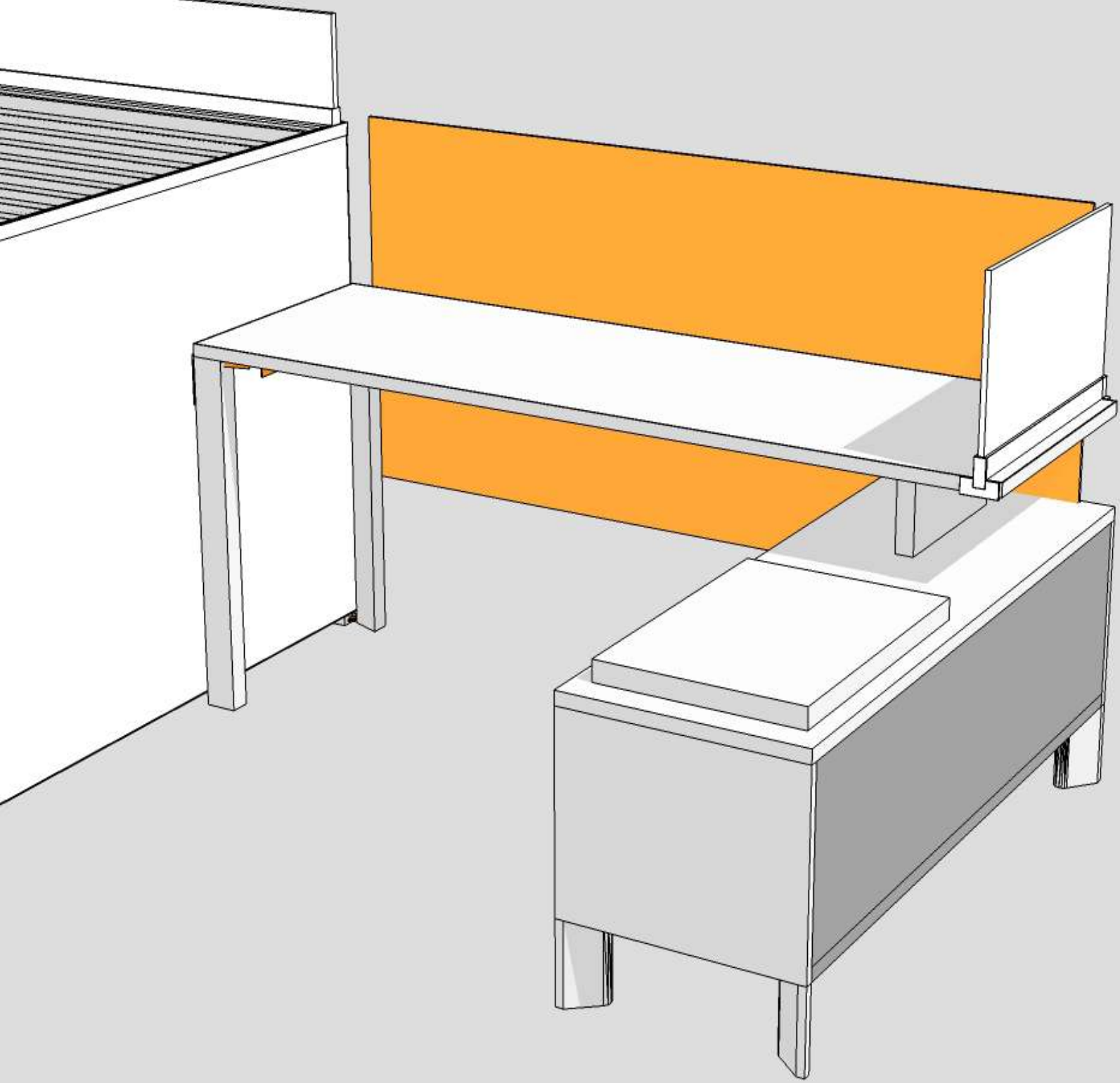

Desk-edge

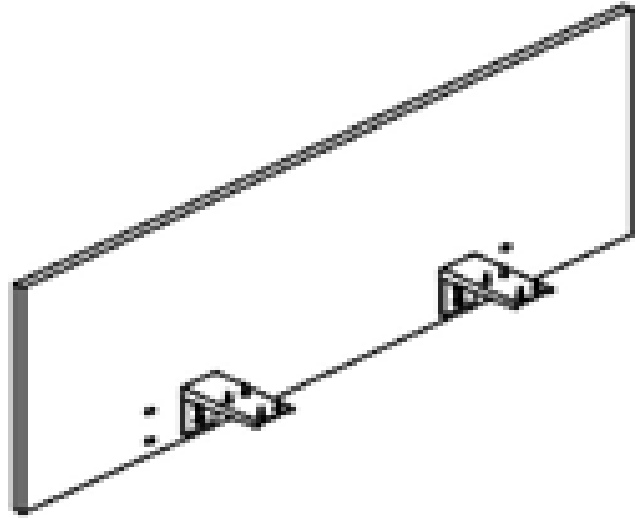

UNSDE: Desk-Edge Screen

Materials:

- Seamless
- Source Laminate
- Smooth Felt (GZDH)
- Acrylic (UNSDEG)

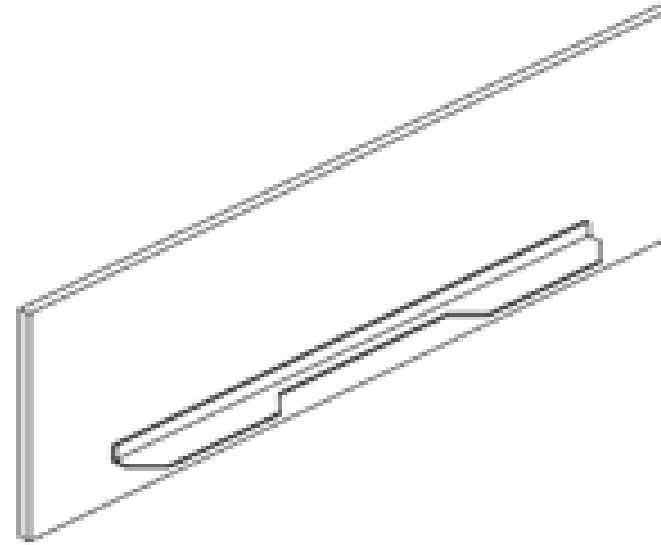

GNSD: Solid Lateral Screen

Materials:

- Seamless
- Source Laminate
- Smooth Felt
- Acrylic

* Product codes shown are examples which can be used when creating CRs.

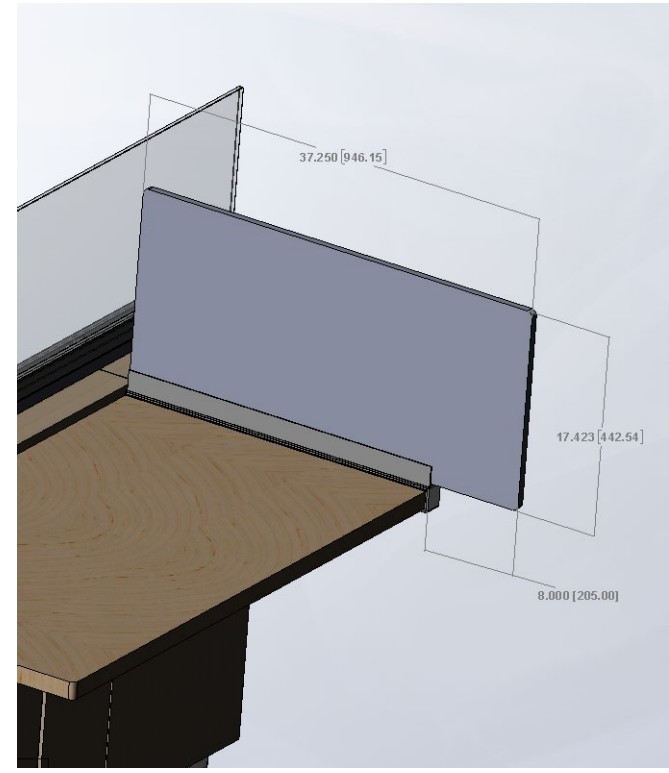

1. WORKSURFACE DEPTH

2. EXTENDED DEPTH

18" HIGH X 37.25" DEPTH
SCREEN – EXTENDS 8"
PAST USER EDGE

Desk-edge

Combination of Desk-Edge and Desk-Top

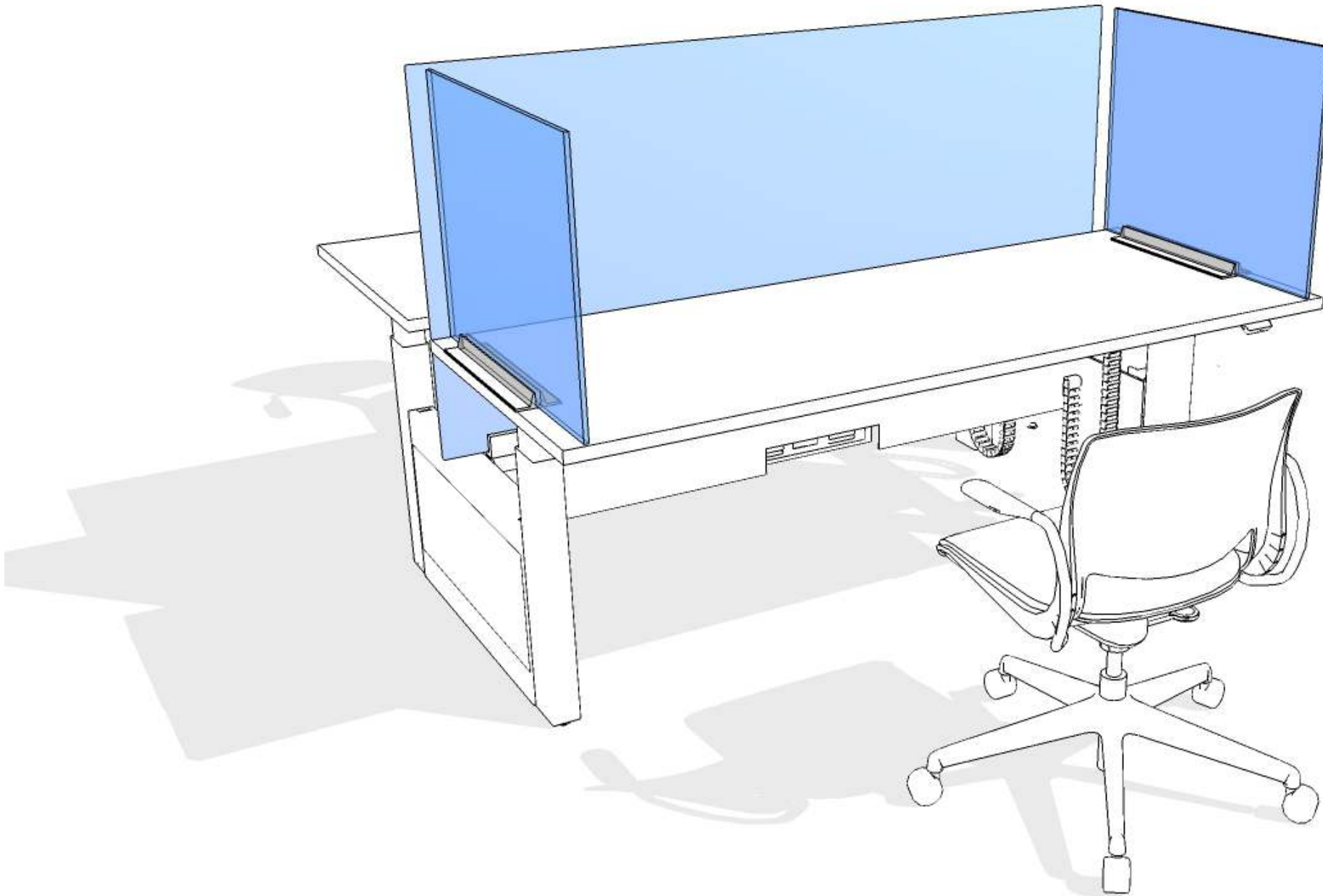

Desk mounted

Worksurface L-screen Kit

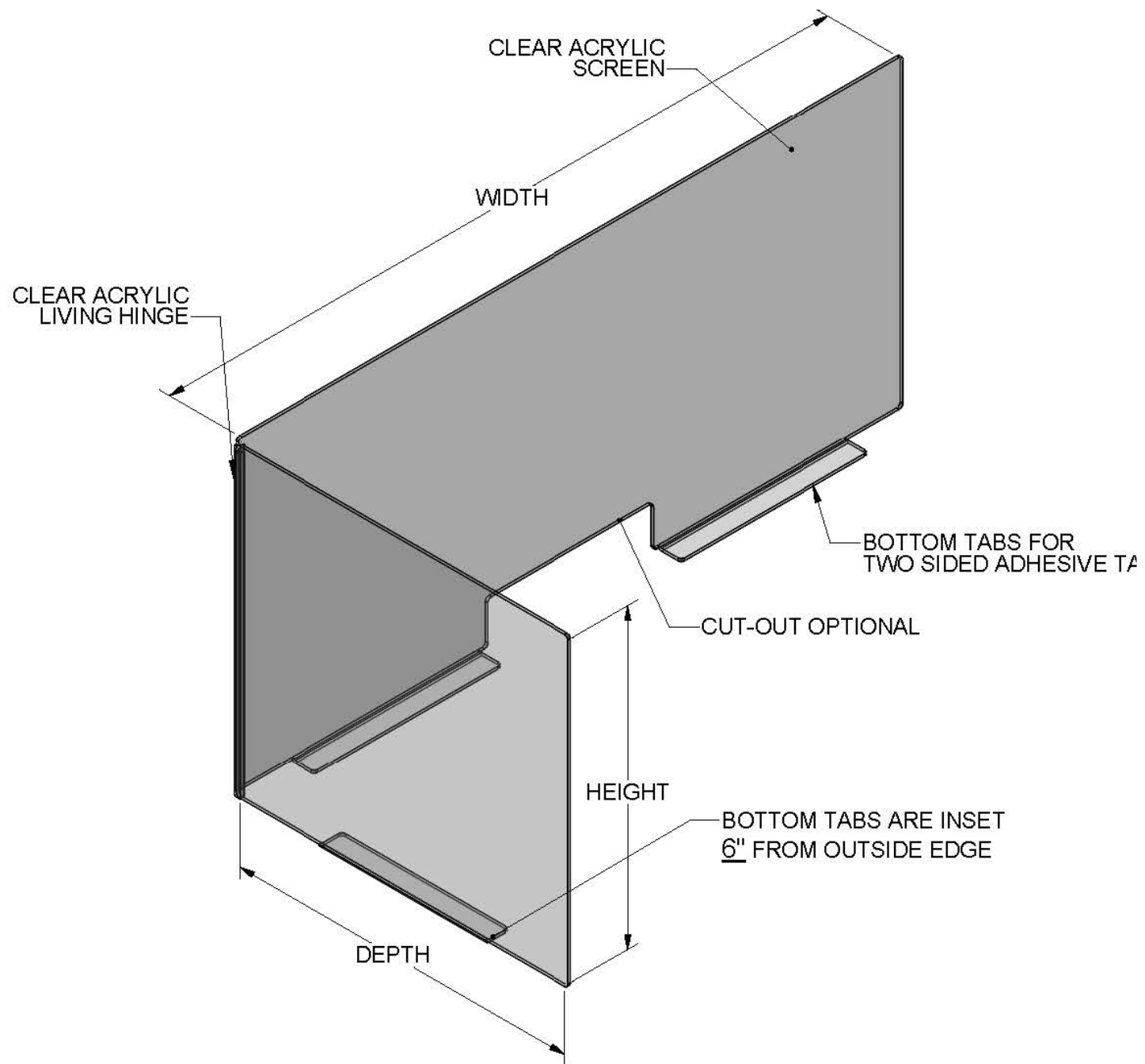

Desk-top

Worksurface U-screen Kit

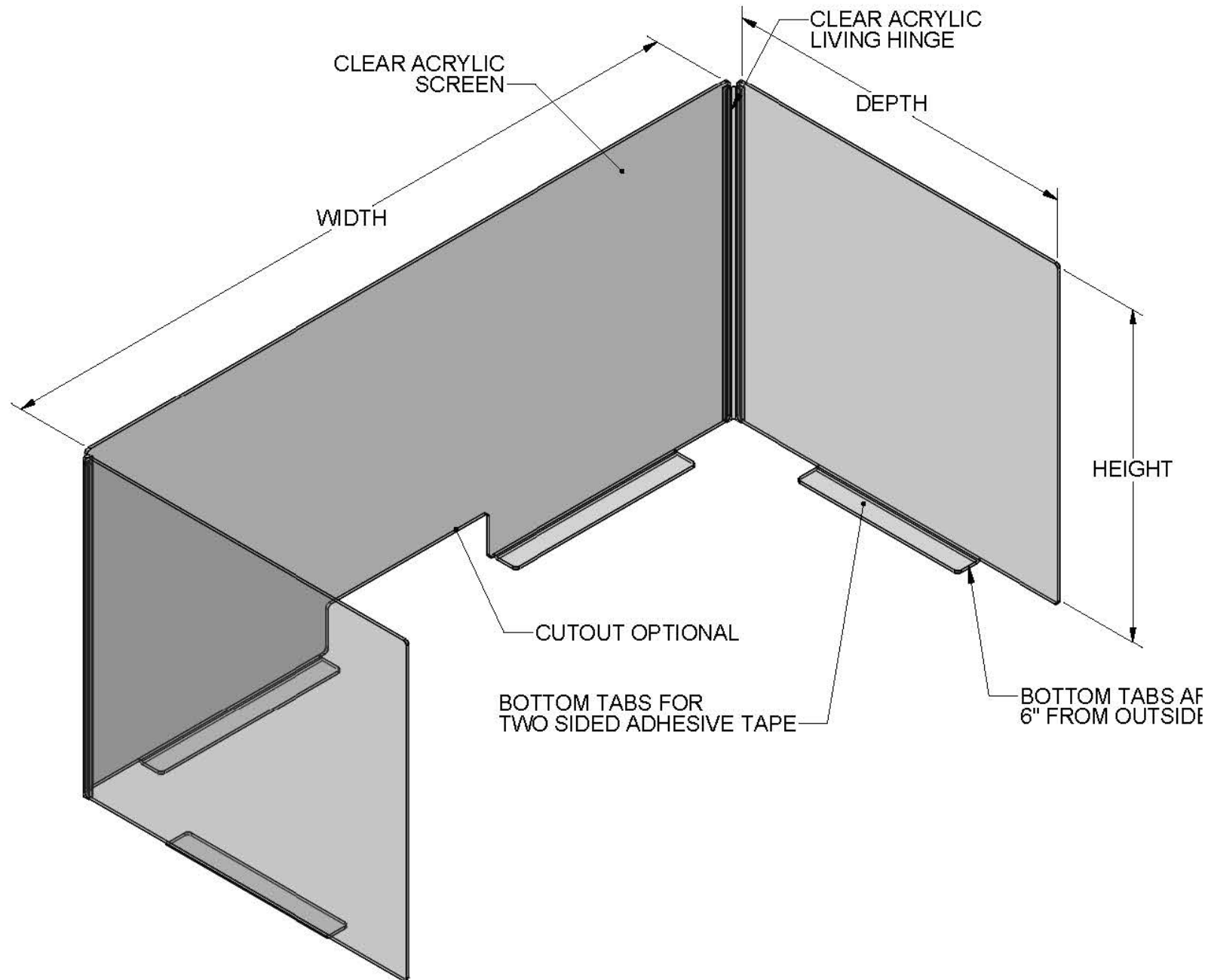

Desk-top



02

FLOOR SCREENS

All floor screen height options:

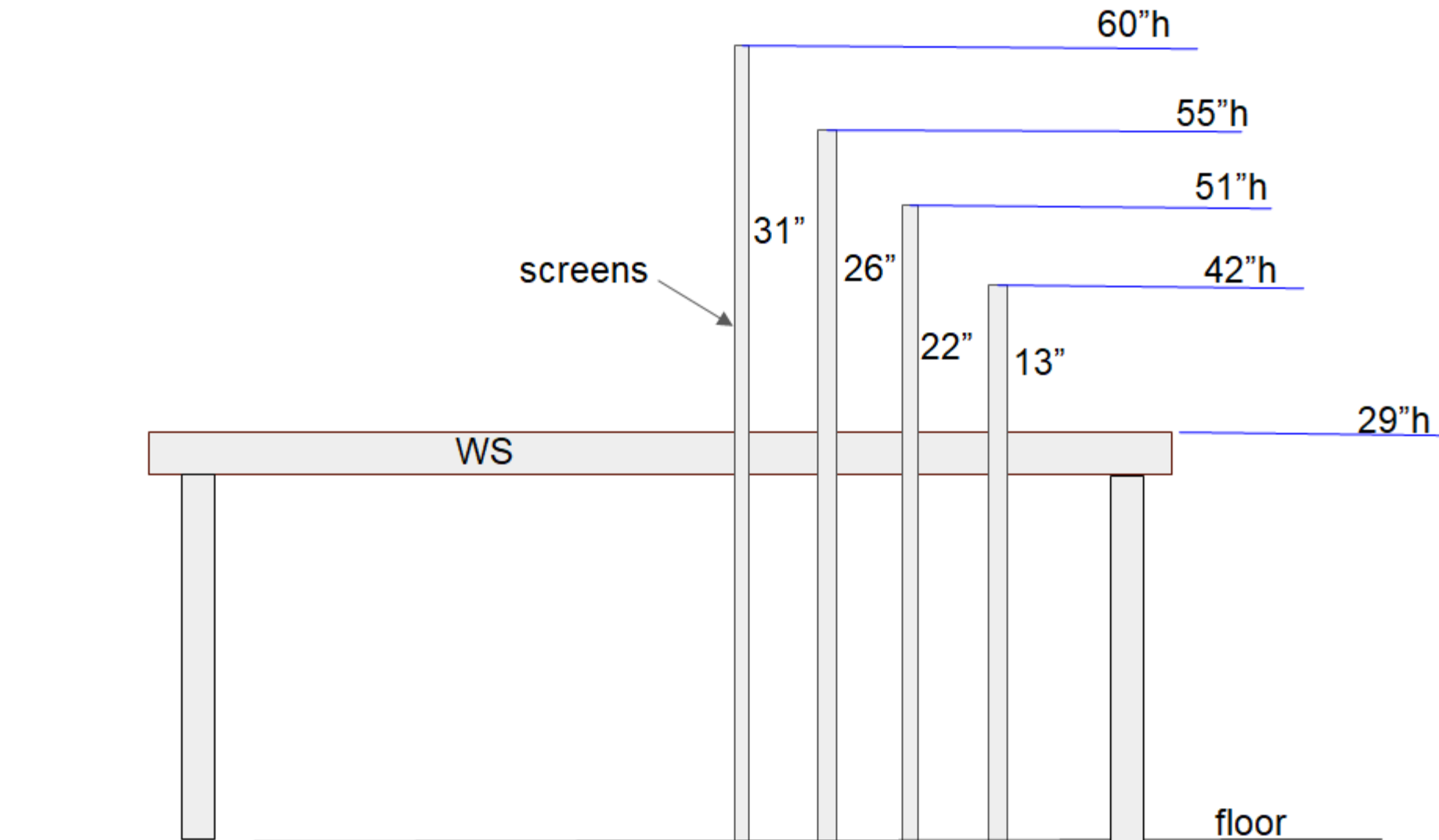

Floor Screen

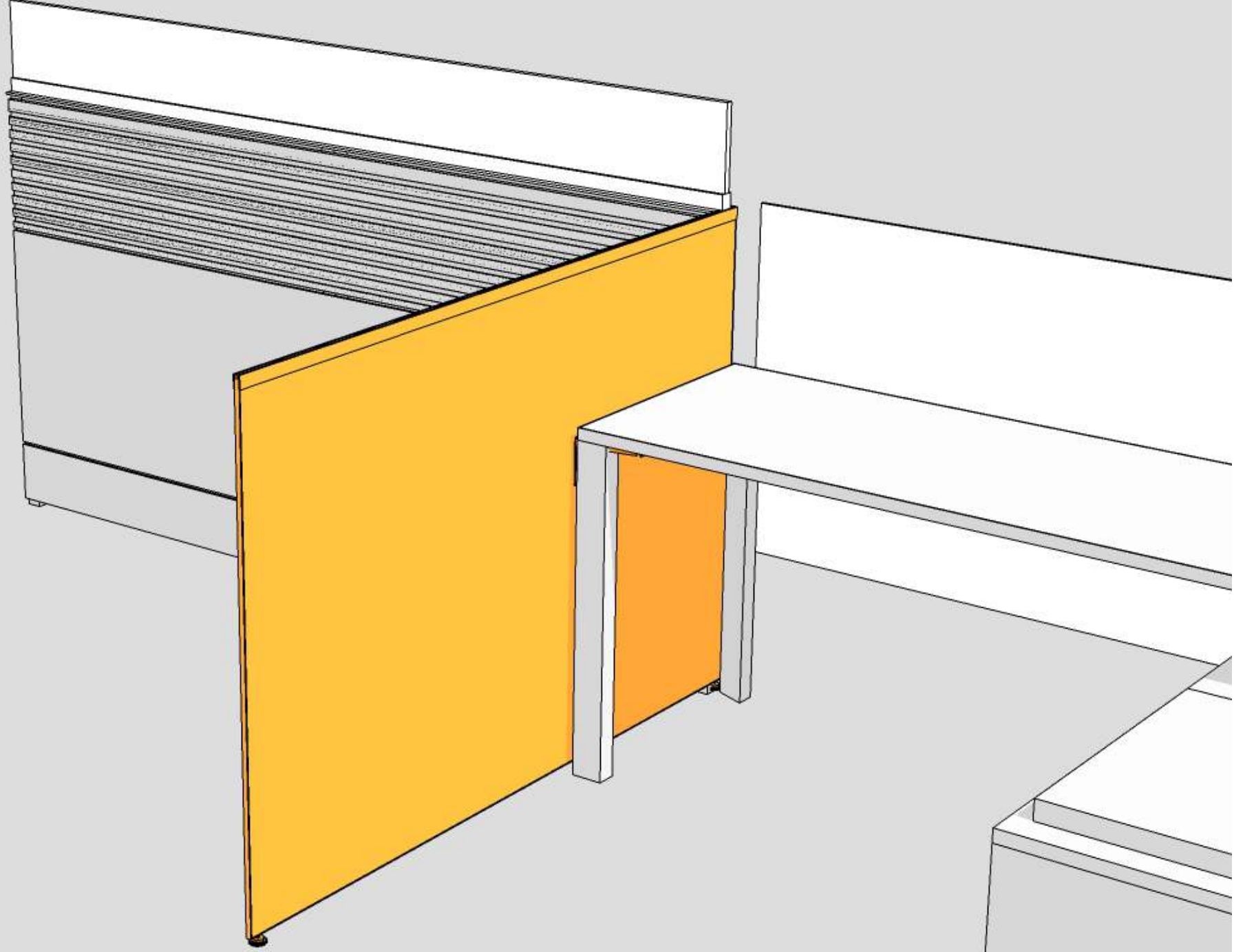

Floor Screen

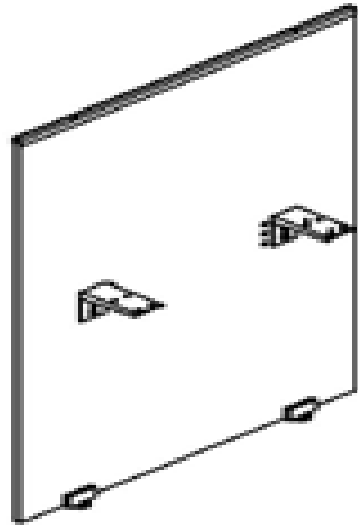

UNSF: Floor Screen

Materials:

Seamless
Source Laminate

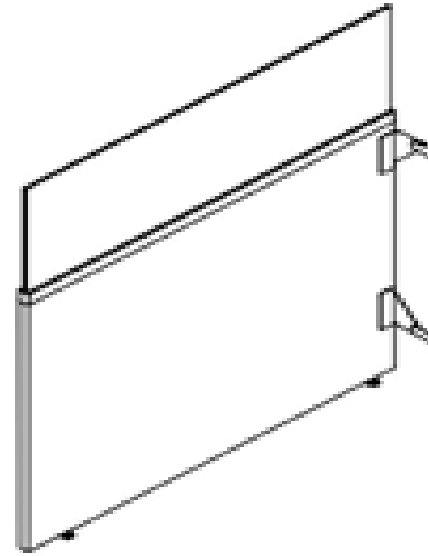

UALSG/S: Lateral Screen with or without glass

Materials:

Seamless
Source Laminate

* Product codes shown are examples which can be used when creating CRs.

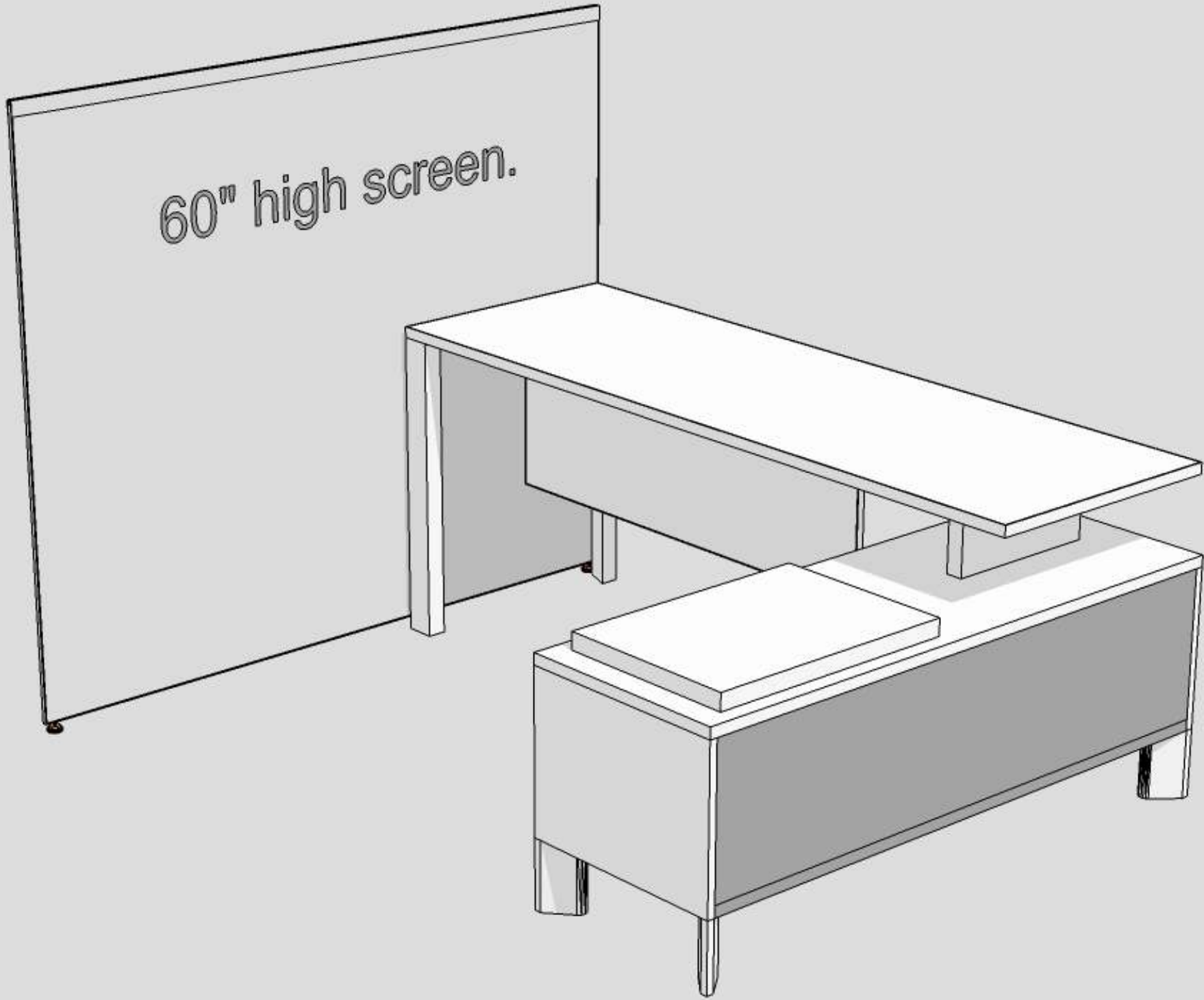

Floor Screen



03

PANEL ADD-ON SCREENS

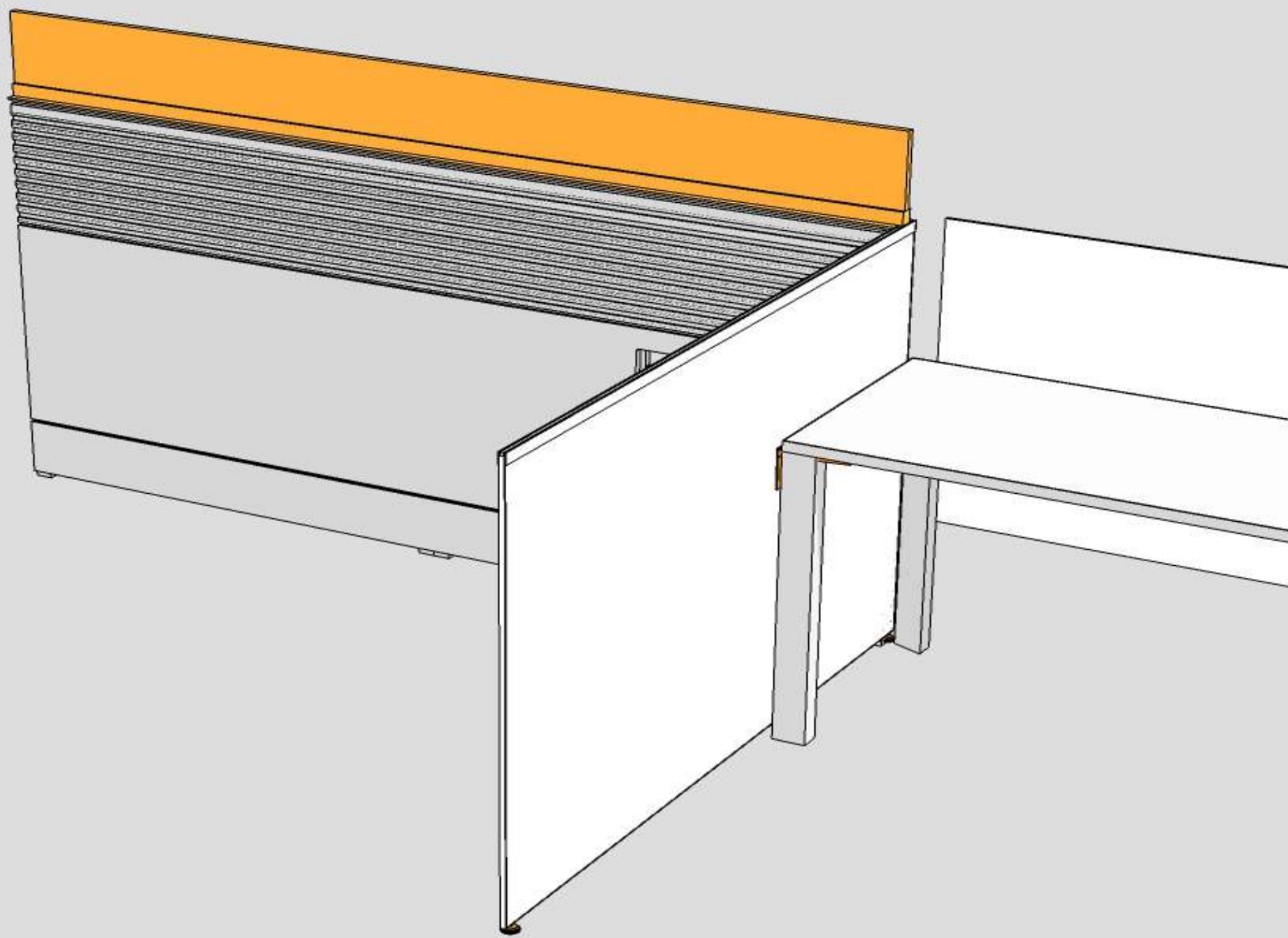

Panel add-on



UNSPG: Panel Wall Add-On Screen

Materials:

Seamless
Source Laminate
Acrylic

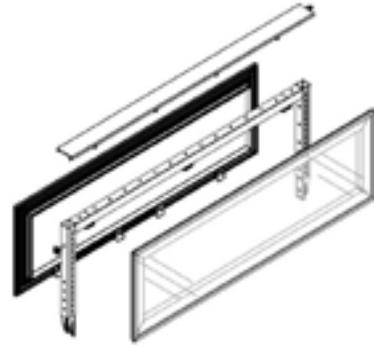

UNPWSR: Panel Add-On Stacker

Materials:

Metal Frame Only



KPGA: Panel Add-On Screen

Materials:

Acrylic

* Product codes shown are examples which can be used when creating CRs.

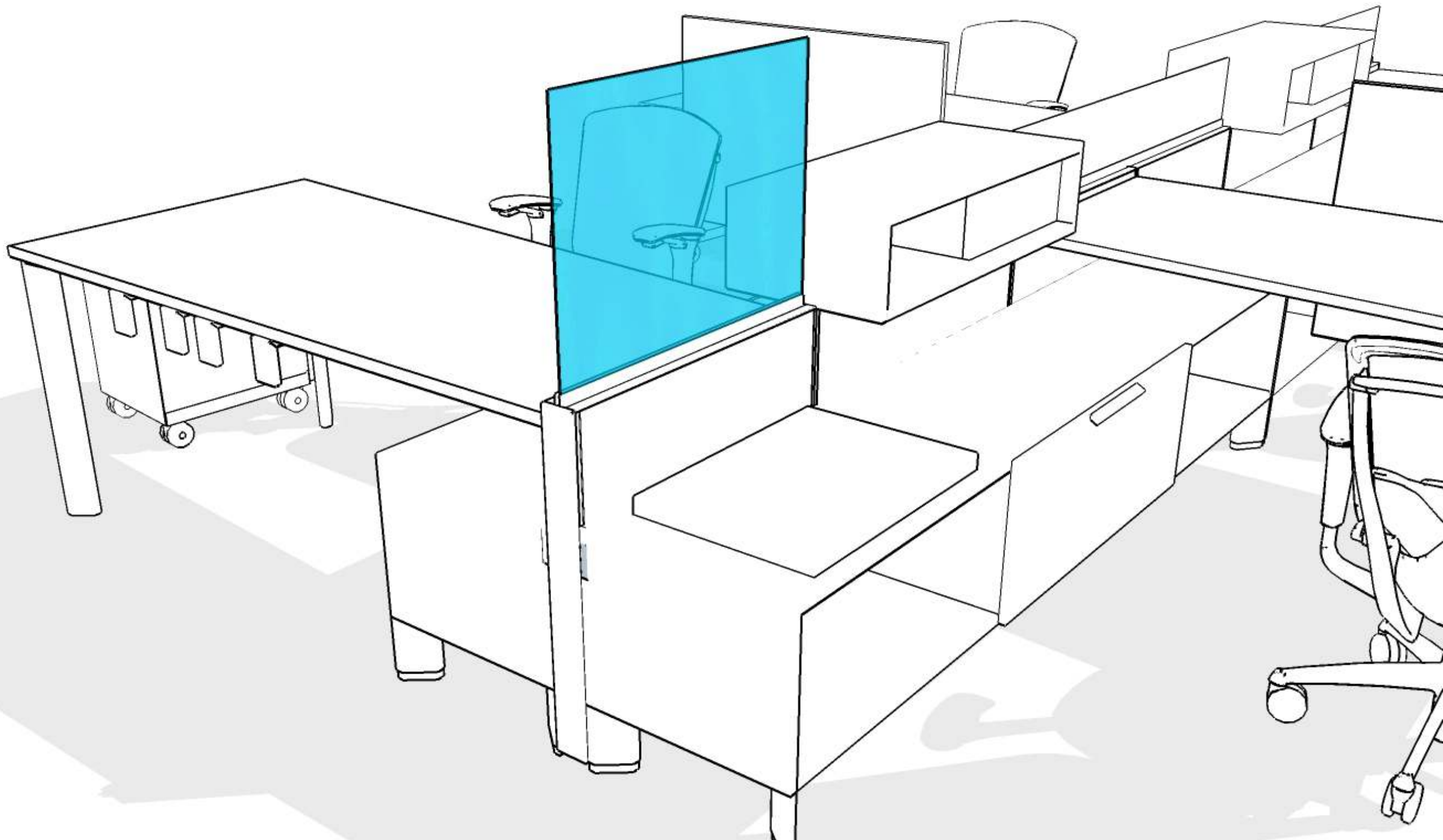



04

NEXT STEPS

1. Create CR's using actual product codes from specific product lines. (see example next page)
 - Application of the special is very important as well as a layout if available.
 - The Price It Pro -Create module located within the Propel APP can assist with -additional . instruction.
2. We recommend that a MOCK UP is placed prior to order submission for oversized screens to assist in viewing the feel and function within the office space.
3. Please contact your local Technical Service group for assistance as needed.
4. If your project requires a large quantity of screens, please obtain lead time confirmation using the Order Preview process.

SAMPLE

Confirmation of Customer Request # 1515558

Customer Name	Screen Special Example		
Product Group	GNGL	Product Code Description	Glass 6mm Lateral Screen
Item Code	GNGL5130	Drawing #	
Customer Product Description	Height 51 51" Datum Height Depth 30 ~C Clear ~Mica Mica Colors ADDITIONAL Special Features -Screen Material to be Acrylic, Not Glass.		
SC Comments			
Pricer Comments			
From Quantity		Price	NOT yet Priced
Region	USA	Currency	US\$
Price Expiration Date	2099/12/31	Special Expiration Date	2099/12/31
Lead Time	0 business days	Est. Order Qty.	100
Attachment	1515558_mid.jpg		
Type Of Special	SpecSpec	Grouping	Sc200501
CR Type	MINOR	Status	PRICING
Enter Date	2020/05/01		
Requester ID	jeremypeacock	Requester Name	Jeremy Peacock
Associated Project(s)			

*** THIS PRICE REQUEST IS NOW EFFECTIVE UNTIL THE NEXT PPG PRICE CHANGE. ***
Teknion reserves the right to delete or change Special Price Requests due to material availability or material price increases.

Ordering



TEKNIOR